

MINIMUM PIPE SUPPORT HEIGHTS

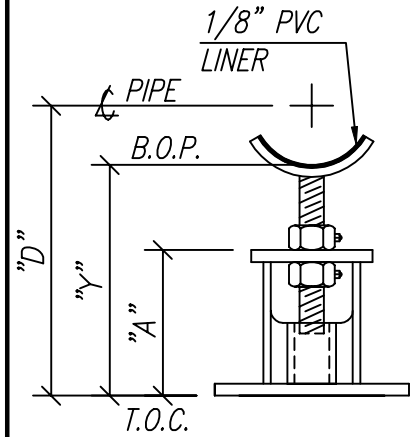
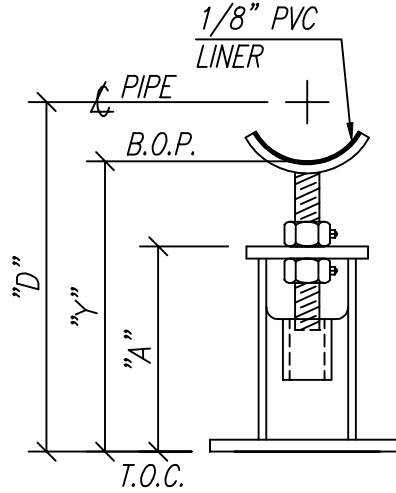
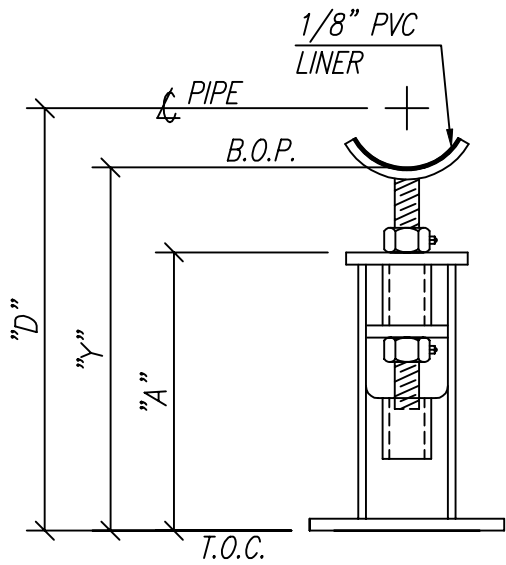

MODEL NO.	PIPE SIZE	STANDARD SUPPORT 2" UP & DOWN TRAVEL		MODIFIED 2" UP & DOWN TRAVEL		MODIFIED 1" UP & DOWN TRAVEL	
		"Y"	"D"	"Y"	"D"	"Y"	"D"
204	2"	1'-2"	1'-3 1/4"	0'-11"	1'-0 1/4"	0'-8"	0'-10 1/4"
	4"	1'-2"	1'-4 1/4"	0'-11"	1'-1 1/4"	0'-8"	0'-11 1/4"
510	6"	1'-2"	1'-5 3/8"	1'-0"	1'-3 3/8"	0'-9"	1'-0 3/8"
	8"	1'-2"	1'-6 3/8"	1'-0"	1'-4 3/8"	0'-9"	1'-1 3/8"
	10"	1'-2"	1'-7 3/8"	1'-0"	1'-5 3/8"	0'-9"	1'-2 3/8"
1218	12"	1'-4"	1'-10 3/8"	1'-1"	1'-7 3/8"	0'-10"	1'-4 3/8"
	14"	1'-4"	1'-11"	1'-1"	1'-8"	0'-10"	1'-5"
	16"	1'-4"	2'-0"	1'-1"	1'-9"	0'-10"	1'-6"
	18"	1'-4"	2'-1"	1'-1"	1'-10"	0'-10"	1'-7"
2024	20"	1'-5"	2'-3"	1'-3"	2'-1"	0'-11"	1'-9"
	22"	1'-5"	2'-4"	1'-3"	2'-2"	0'-11"	1'-10"
	24"	1'-5"	2'-5"	1'-3"	2'-3"	0'-11"	1'-11"
2636	26"	1'-5"	2'-6"	1'-3"	2'-4"	1'-0"	2'-1"
	28"	1'-5"	2'-7"	1'-3"	2'-5"	1'-0"	2'-2"
	30"	1'-5"	2'-8"	1'-3"	2'-6"	1'-0"	2'-3"
	32"	1'-5"	2'-9"	1'-3"	2'-7"	1'-0"	2'-4"
	36"	1'-5"	2'-11"	1'-3"	2'-9"	1'-0"	2'-6"

"Y" = B.O.P. (BOTTOM OF PIPE TO TOP OF CONCRETE)
"D" = C.O.P. (CENTERLINE OF PIPE TO TOP OF CONCRETE)

E-Z LINE PIPE SUPPORT CO., INC.
 MANVEL, TEXAS (713) 675-6693

SCHEDULE FOR MINIMUM PIPE SUPPORT HEIGHTS

SHEET
SCH-MIN